

## 04.2 DC motor driving

1 There are two common methods of driving DC motors: (a) with a digital motor driver and (b) with an analog amplifier. Schematics of both are shown in Fig. 04.1.

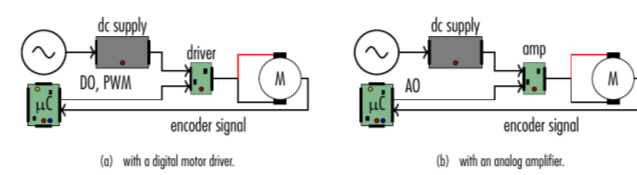

Figure 04.1: two common methods of driving motors.

### Digital motor drivers

2 A microcontroller such as the myRIO or Arduino can easily produce a PWM signal, which, as we saw in Lec. 04.1, can be averaged by a system's dynamics such that varying the duty cycle varies the averaged signal. However, microcontrollers are low-power and cannot drive even small DC motors. Therefore it is common to include a special kind of integrated circuit (IC) that uses the microcontroller's low-power PWM signal to gate a high-power DC source signal for delivery to the motor. These are called digital motor drivers; a common system setup with a motor driver is shown in Fig. 04.1(a). They deliver power from a high-power source in accordance with a PWM signal, and they often include many additional features such as

1. compact forms;
2. forward- and reverse-driving (see Lec. 04.2)
3. protection against reverse voltage, overcurrent, and overheating; and
4. output pins that monitor delivered current and voltage.

3 These digital motor drivers are sometimes called class-D or switching amplifiers. Generally, they are inexpensive and are quite efficient (around 92% in some cases), which, in addition to conserving power, adds the capacity of delivering high-power operation or requiring lower heat dissipation (or a "Goldilocks" mixture thereof).

### H-bridge circuits

4 We want to drive DC motors at different effective voltages and different directions. An H-bridge circuit allows us to reverse the direction of the PWM signal delivered to the motor. Fig. 04.2 is a diagram of the H-bridge circuit.

5 The switches S1-S4 are typically instantiated with MOSFET transistors. As shown in the figure below, during the high duration of the PWM pulse, either S1 and S4 (Fig. 04.2(b)) or S2 and S3 (Fig. 04.2(c)) are closed and the others are open.

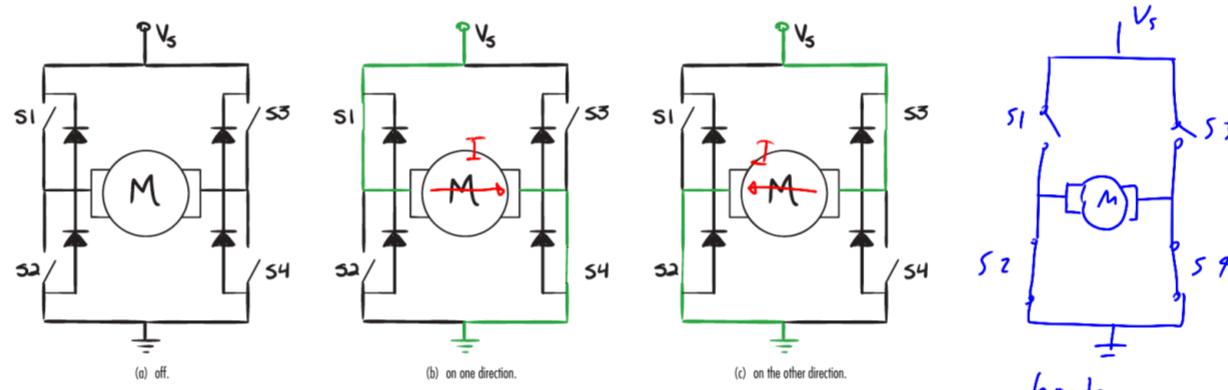

Figure 04.2: H-bridge operation.

6 Recall that the electronics side of a DC motor can be modeled as a resistor and inductor in series with an electro-mechanical transformer. The inductance of the windings make it an "inductive" load, which presents the following challenge. We can't rapidly change the current flow through an inductor without a huge spike in voltage, and the switches do just that, leading to switch damage. Therefore, during the low or "off" duration of the PWM signal, S1-S4 cannot all be simply opened. There are actually a few options for switch positions that allow the current to continue to flow without inductive "kickback."

7 What's up with the diodes? Technically, they could be used to deal with the kickback. But since the diodes dissipate power, the proper switching is the primary kickback mitigation technique. However, the diodes ease the transition between switch flips, which are never quite simultaneous.

### Analog amplification

8 An alternative to digital motor drivers are analog amplifiers, which require a slightly different setup, shown in Fig. 04.1(b). This setup requires an analog signal from the microcontroller, a digital device. Therefore, the microcontroller performs a process called digital-to-analog conversion (DAC), treated further in Lec. 06.1 and Resource 14. Many microcontrollers have this functionality and can produce analog signals over ranges such as  $\pm 10$  V, the range of the myRIO's Q1 channel analog outputs.

9 An amplifier essentially "adds power" to the microcontroller analog output from an external power source. There are several varieties that can operate as voltage/current-controlled voltage/current sources within a range of operation. When that range is exceeded, operation typically becomes nonlinear and finally saturates (increased input does not increase output). Saturation is, of course, one of several considerations when designing with amplifiers.

10 A comparison between digital motor drivers and analog amplifiers is given in Table 04.1. For more, see (Collins, 2018).

Table 04.1: comparison between digital motor drivers and linear analog amplifiers.

feature	digital motor driver	analog amplifier
cost	less expensive	more expensive
signal noise	noisy	minimal
audible noise	load	none
low-signal fidelity	poor	good
high-precision control	poor	good
efficiency	90%	50%
heat generation	low	high
high-powered	> 100 W	< 100 W
brushed/less dc	good	good
H-bridge	required	not required

### The ECL installation

11 The Embedded Computing Lab (ECL) has both digital motor drivers and linear analog amplifiers, both of which are commercially available.

### Digital motor drivers

12 For a digital motor driver, we use a connectorized printed circuit board (PCB)—the Pololu motor driver carrier:

[pololu.com/product/1451](http://pololu.com/product/1451)  
[ricopic.one/resources/pololu\\_VNH5019.pdf](http://ricopic.one/resources/pololu_VNH5019.pdf)  
 (manual)

This includes an STMicroelectronics VNH5019 H-bridge motor driver integrated circuit:

[ricopic.one/resources/vnh5019.pdf](http://ricopic.one/resources/vnh5019.pdf).

13 This type of motor driver is commonly found in small-motor applications such as those in an automobile used for adjusting seat, window, and mirror positions.

### Analog amplifiers

14 The Copley Controls 412 voltage-controlled current source (or transconductance) amplifiers in the ECL are actually switched amplifiers, internally (so they're relatively efficient and capable of high-power), but function as analog amplifiers. This is a standard type of motor amplifier found in industrial settings. The device manual can be found here:

[ricopic.one/resources/Copley412.pdf](http://ricopic.one/resources/Copley412.pdf).

15 For the amplifier settings used in the ECL, see Resource 10.