

ss.exe Exercises for Chapter ss

Exercise ss.7

Draw necessary sign coordinate arrows, a linear graph, a normal tree, and identify state variables and system order for each of the following schematics.

- a. electronic system, current source

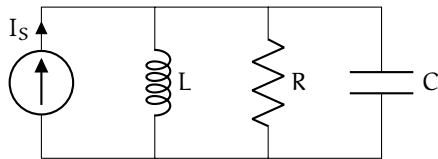

- b. rotational mechanical system, torque source

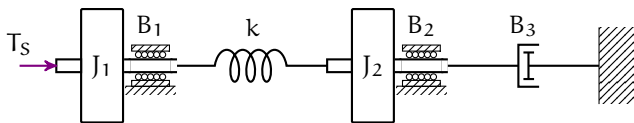

- c. translational mechanical system, velocity source

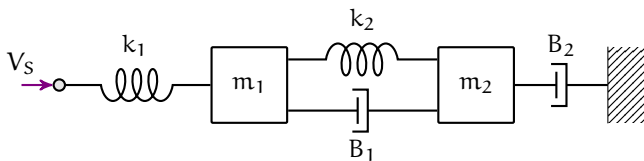

Exercise ss.8

Draw necessary sign coordinate arrows, a linear graph, a normal tree, and identify state variables and system order for each of the following schematics.

- a. electronic system, voltage source

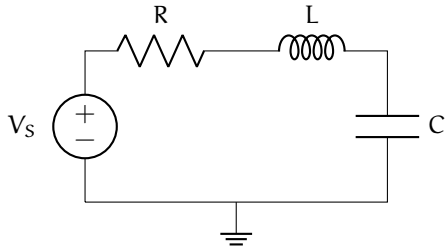

b. rotational mechanical system, angular velocity source

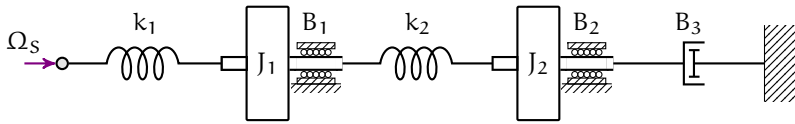

c. translational mechanical system, force source

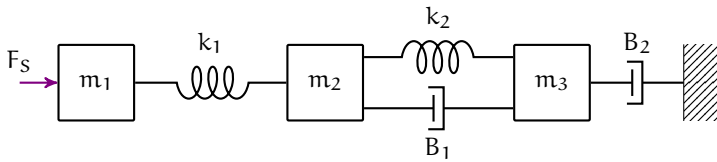

Exercise ss.9

Draw necessary sign coordinate arrows, a linear graph, a normal tree, and identify state variables and system order for each of the following schematics.

a. electronic system, voltage source

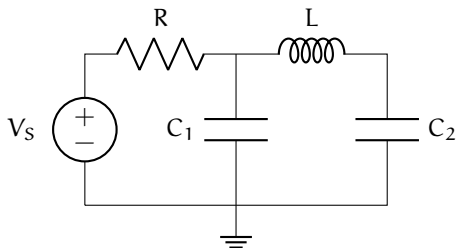

b. rotational mechanical system, torque source

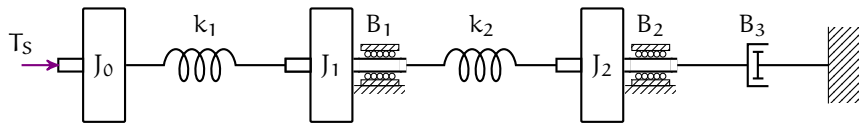

c. translational mechanical system, force source

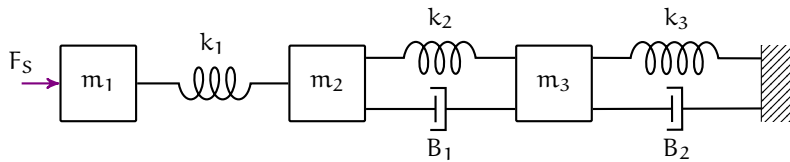

Exercise ss.11

Use the following linear graph for a circuit to answer the questions below, which are the steps to determining a state-space model of the circuit. Use the sign convention from the diagram. V_s is a voltage source.

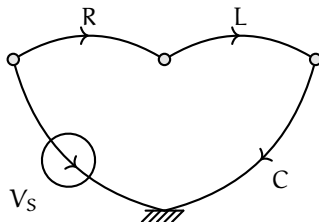

- Determine the normal tree, state variables, system order, state vector, input vector, and output vector for the outputs i_R and v_C .
- Write the required elemental, continuity, and compatibility equations.
- Solve for the state equation in standard form.
- Solve for the output equation in standard form.

Exercise ss.12

Use the following linear graph for a mechanical translational system to answer the questions below, which are the steps to determining a state-space model from the linear graph. Use the sign convention from the diagram. F_S is a force source. Let the outputs be v_m and f_k .

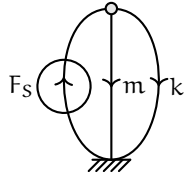

- Determine the normal tree, state variables, system order, state vector, input vector, and output vector.
- Write the required elemental, continuity, and compatibility equations.
- Solve for the state equation in standard form.
- Solve for the output equation in standard form.

Exercise ss.13

Use the following linear graph for a mechanical rotational system to answer the questions below, which are the steps to determining a state-space model from the linear graph. Use the sign convention from the diagram. T_S is a torque source. Let the outputs be Ω_J and T_B .

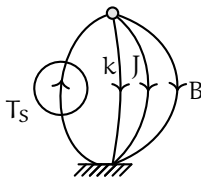

- Determine the normal tree, state variables, system order, state vector, input vector, and output vector.

- b. Write the required elemental, continuity, and compatibility equations.
- c. Solve for the state equation in standard form.
- d. Solve for the output equation in standard form.

Exercise ss.blowhard

Use the following linear graph for a mechanical rotational system to answer the questions below, which are the steps to determining a state-space model from the linear graph. Use the sign convention from the diagram. Ω_S is an angular velocity source. Let the outputs be the angular velocity Ω_J of the inertia and the angular displacement θ_k across the spring.

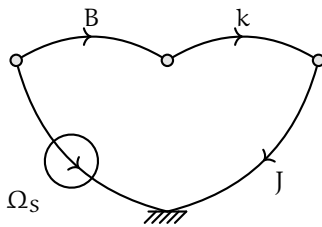

1. Determine the normal tree, state variables, system order, state vector, input vector, and output vector.
2. Write the required elemental, continuity, and compatibility equations.
3. Solve for the state equation in standard form.
4. Solve for the output equation in standard form.

Exercise ss.chunker

Use the assigned coordinate arrows to draw a linear graph, a normal tree, and identify state variables and system order for each of the following schematics.

1. electronic system, voltage and current source

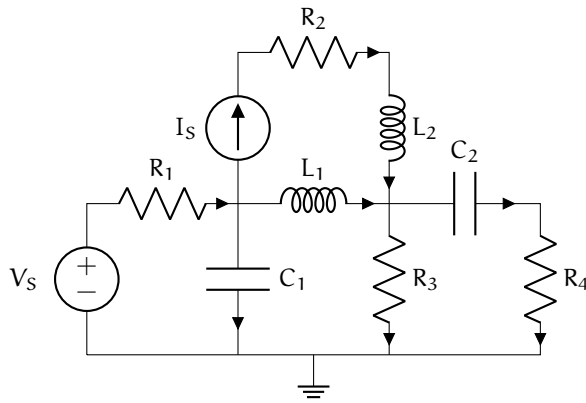

2. rotational mechanical system, torque source, coordinate arrow

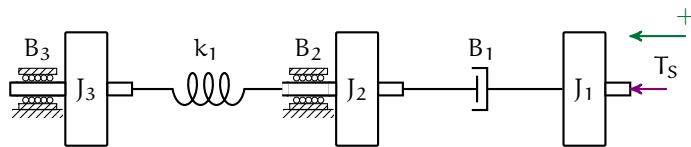

3. translational mechanical system, force sources (2)

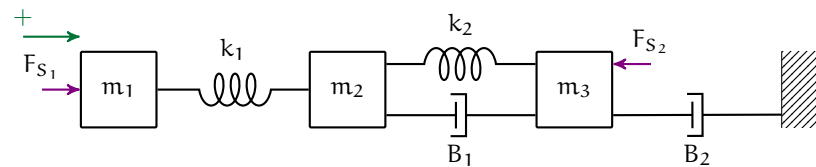

Exercise ss.granada

Use the assigned coordinate arrows to draw a linear graph, a normal tree, and identify state variables and system order for each of the following systems.

_____/35 p.

1. rotational mechanical system, two torque sources

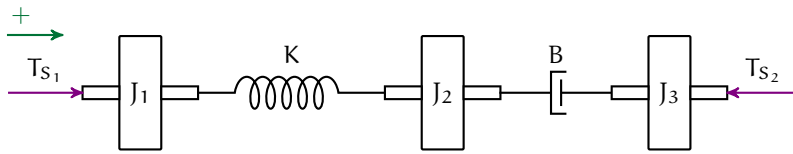

2. translational mechanical system, velocity source

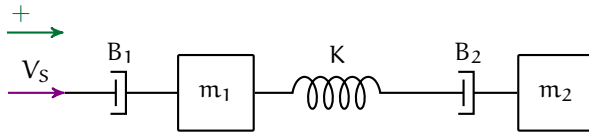

Exercise ss.valencia

Use the following linear graph for a mechanical translational system to answer the questions below, which are the steps to determining a state-space model from the linear graph. ———/50 p.

Use the sign convention from the diagram. F_S is a force source. Let the outputs be v_{m_1} and v_{m_2} .

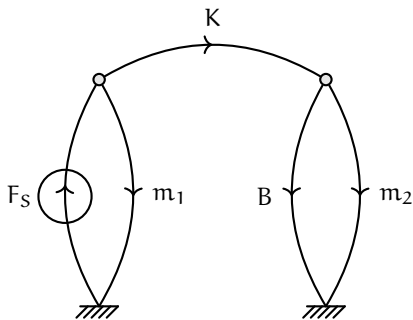

1. Determine the normal tree, state variables, system order, state vector, input vector, and output vector.
2. Write the required elemental, continuity, and compatibility equations.
3. Solve for the state equation in standard form.
4. Solve for the output equation in standard form.

emech

Electromechanical systems