

lti.ghost When gravity ghosts you

1 You're familiar with experience. Just when you think you're getting along so well with a "vertically" oriented translational mechanical system, gravity stops answering your texts. In this lecture, I'll try to explain this common experience: it seems that sometimes the force of gravity "matters," and other times it does not. Is gravity really Hamletic, an ambivalent vixen, or is there some way to understand this phenomenon?

2 Consider the following example contrived to shed some light.

Example lti.ghost-1

3 Often when considering a spring k , we focus on the velocity v_k across it, i.e. the time-derivative of the displacement x_k . We effectively differentiate-away the constant unstretched length L from x_k ; we can think of

$$x_k - L \quad (1)$$

as the "stretch" of the spring. In this exercise, we will attend closely to the details of this stretching.

4 Consider the mechanical harmonic oscillator shown in Fig. ghost.1. Derive a single input-output ODE for the system in terms of x_k , the total displacement across the spring. Let the constant \tilde{L} be the stretched length of the spring when the system is in static equilibrium. Solve for \tilde{L} in terms of the system parameters. Show that when we change ODE dependent variable from x_k to

$$\tilde{x}_k = x_k - \tilde{L}, \quad (2)$$

- the displacement from equilibrium, gravity
- ghosts us!

re: state-space model of a harmonic oscillator

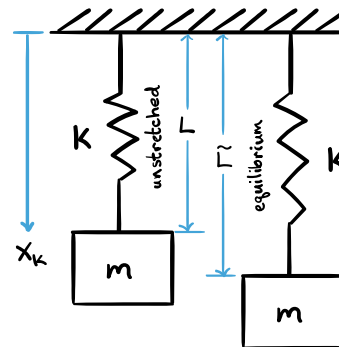

Figure ghost.1: a mechanical harmonic oscillator with spring k unstretched (left) and stretched (right) to its static equilibrium length.

5 For this example, there is a much shorter way to deriving the system ODE than our usual approach, and we will use it here: the traditional free-body diagram application of Newton's laws, shown in Fig. ghost.2. Applying Newton's second law,

where the forces are

(when $x_k > 0$, $f_k < 0$)

Substituting in the forces,

6 Equilibrium implies $\ddot{x}_k = 0$ and $x_k = \tilde{L}$, therefore

7 Changing variables à la Eq. 2 in the ODE yields

Alas, poor ghost!

8 We have seen now that the gravitational

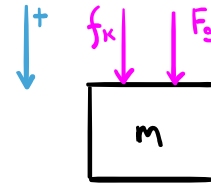

Figure ghost.2: a free-body diagram of the mass.

ghosting occurs when we change variables such that the displacement is relative to an equilibrium in the gravitational field. It is simply a change of datum or reference position of the displacement that cancels out the gravitational term—ay, there's the rub! We call this the equilibrium requirement.

9 For this reason, those performing such analyses, with a flourish of the hand, declare vertical displacements relative to equilibrium and poof—gravity disappears without explicit justification, for the details make cowards of us all.

10 But there are situations in which this would be a fatal error: those for which there is _____! For instance, consider if the mass in our previous example was suspended from a damper instead of a spring: in this case, no equilibrium exists! Without going through the details or at least recalling the equilibrium requirement, it can be easy to fool oneself into wrongly dismissing gravity.

11 Remember me,
Ghost-would-be,
For I am thy father's spirit,
If gravity'd,
With thee flee,
Th'equilibrium requirement.

datum

equilibrium requirement



Figure ghost.3: to ghost or not to ghost, that is the question.